



Heating pump assembly PrimoTherm® K 180-2 DN25 WP 3WM-SM

Part no. 77814

Heating pump assembly

benefits

- pre-assembled, tightness-tested and heat-insulated assembly
- with high-grade, robust mixer
- Version with adjustable flow coefficient Kvs from 2.5 to 12 m³/h: Adjustment also possible during operation (under pressure) at any time
- available with high energy efficiency pump class A



Application

Heating pump assembly for use in mixed heating circuits. With the 3-way mixer and the actuator, the flow temperature can be adjusted to a desired temperature by adding water from the return. The mixer version with adjustable flow coefficient Kvs offers maximum flexibility in adapting the system to individual control requirements. The flow coefficient Kvs can be modified at any later point in time, even if the system is under pressure. This way, a great variety of mixer/pump assemblies can be covered with a single version.

Description

Compact, pre-assembled and tightness-tested heating pump assembly with all required functional components, form-fit heat insulation (complies with German Energy Saving Regulation) and wall mounting unit. Adhesive labels with pictograms allow for easy designation.

The flow line consists of:

Combination valve with thermometer in the hand wheel (red mark, range 0/120 °C)

3-way mixing valve with ProClick adapter system, either ARV 325 with flow coefficient Kvs 12 m³/h or KVS Vario with adjustable flow coefficient Kvs

Maintenance-free, silent actuator ARM 343 (6 Nm, 120 s, AC 230 V) with 0/90° angle of rotation, indication for direction of rotation, selector key "Manual/Automatic Mode" and ProClick adapter system

System connection G1½ male (boiler), G1 female (heating circuit) Suitable for pumps DN 25 with G1½ x 180 mm.

The return line consists of:

Combination valve with gravity brake, thermometer in the handle (blue mark, range 0/120 °C)

Pipe for length compensation as T piece for mixer connection with screw connection for system connection

System connection G1½ male (boiler), G1 female (heating circuit)

Technical Specifications

Axis distance

125 mm

system connections

Boiler: G1½ male
Heating circuit: G1 female

Operating temperature range

Medium: max. 95 °C
Medium: short-term 120 °C

System pressure

max. 10 bar

Nominal size

DN 25

Flow coefficient Kvs

12 m³/h

Heat insulation

Polypropylene EPP

Dimensions

W x H x D: 248 x 400 x 155 mm

Circulation pump

Wilo Para RS 25–180/6

Length

180 mm

Degree of protection

IP 44 (EN 60529)

Supply voltage

AC 230 V, 50 Hz

Energy efficiency class

A

Power input

Wilo Para RS 25–180/6
3 – 43 W

pumping head

Wilo Para RS 25–180/6
max. 6.7 m

pumping volume

Wilo Para RS 25–180/6
max. 3.2 m³/h

operating modes/settings

Wilo Para RS 25–180/6
constant volume flow PP (3),
constant pressure CP (3),
constant speed of rotation CC (3)

Technical Drawings

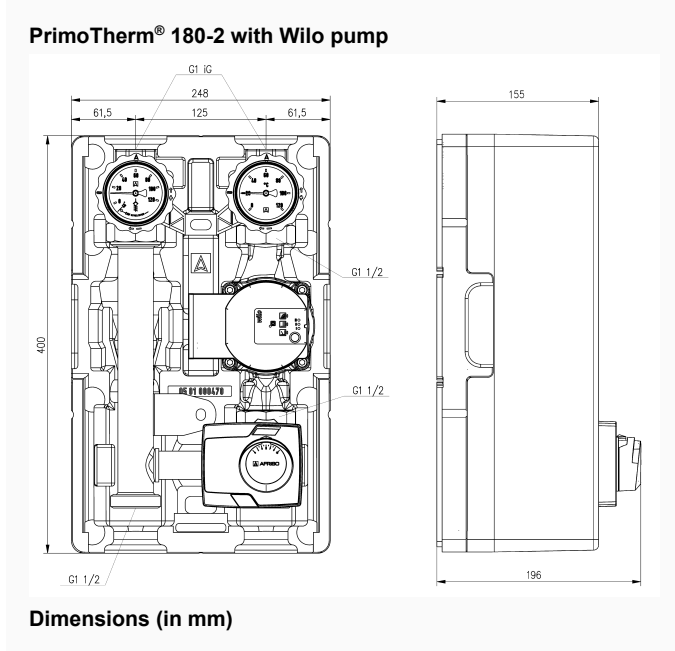

Versions

	opening temperature is reached	Pump		Part no.
Heating pump assembly PrimoTherm® K 180-2 DN25 WP 3WM-SM		Wilo Para RS 25-180/6	●	77814

- in-stock items
- Non-stock items