

motorised actuator MSA 10 DT

Part no. 79540

motorised actuator for hydraulic balancing



benefits

- install and you're done! Dynamic hydraulic balancing all year round
- eligible for heating optimization program (BAFA)
- First Open function
- universal application in existing and new buildings
- suitable for heating and cooling
- probe position detected automatically, therefore impossible to confuse



Application

Actuator for automatic hydraulic balancing and energy-saving operation of surface heating systems. Suitable for controlling hot water valves in manifold systems such as the AFRISO heating/cooling system manifold ProCalida® MC, EF, VA and IN. Thanks to valve displacement detection and precise valve control, the actuator can also be used universally on existing manifolds. The adaptive PID control algorithm of the continuous controller controls the flow rate based on the measure flow and return temperatures for hydraulic balancing all year round, even during partial load operation of the heating system.

The actuator is factory-opened (First Open function) so that the stroke valves at the heating circuit manifold remain open during initial commissioning. This facilitates mounting as well as filling and flushing of the system since, at this point in time, the control system is usually not yet operative. The First Open function (FO) is automatically disabled as soon as the actuator is electrically controlled. The FO function can be re-enabled via a reset.

Description

Motorised, actuator with temperature-dependent control, with First Open and Re-Open function, LED indicator and two probe cables. Direct connection to the valve or upper part of the valve with union nut. Control via the supply voltage (230 V / 24 V) of the control terminal bar. Low power consumption, since the motor only requires energy when it actually moves. MSA automatically detects which probe is used as the flow or return probe.

Technical Specifications

functions

first-open function (can be re-enabled),
closing point detection by homing movement during initial activation

Operating mode

closed when de-energised (NC)
Condition as delivered: Open

control stroke

4.5 mm

Closing dimension
10.5 mm

Actuating force
110/150 N

Connection
union nut M30 x 1.5 mm (Brass, nickel-plated)

Housing
Plastic PA 6, flame retardant
Degree of protection: IP 54 (EN 60529)
cap: white

cable
2 x 0.75 mm², white
Length: 0.9 m

Temperature probes
fastening by means of pipe clip, cannot be confused
cable length 0.4 m

Operating temperature range
Operation: max. 50 °C (at valve)
Ambient: 0/50 °C
Storage: -25/+60 °C
ambient humidity: < 85 % rH, Non-condensing

Supply voltage
AC 230 V

power input continuous operation
AC 230 V
< 1 W

Switch on power
AC 230 V

Inrush current
30 mA

Protection class
AC 230 V
II (EN 60730-1)

Dimensions (H x W x D)
95.3 x 37.8 x 53.2 mm

Weight
186 g

Technical Drawings

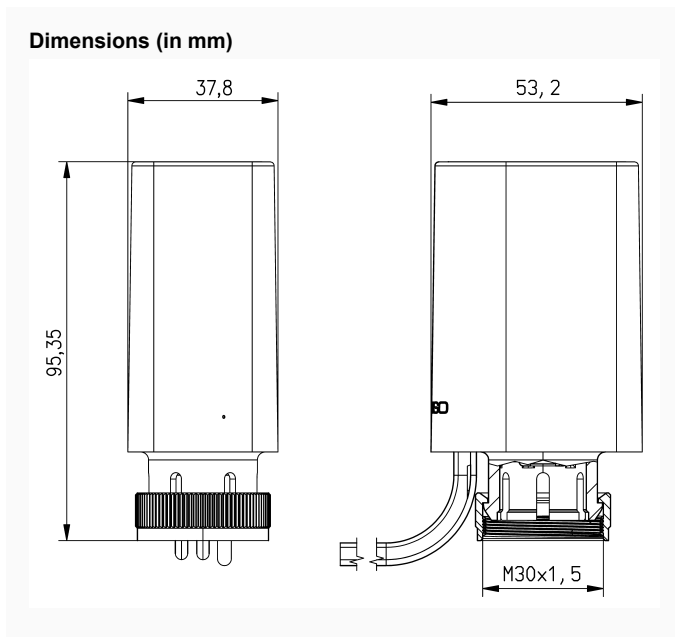

Versions

			Part no.
motorised actuator MSA 10 DT	AC 230 V	<input checked="" type="radio"/>	79540

- in-stock items
- Non-stock items