

Verwendung

CNC-Werkzeugmaschinen, Präzisionsbearbeitungsmaschinen, Hochgeschwindigkeitsanlagen, elektronische Produktionsanlagen, medizinische Geräte

Use

CNC machine tools, precision machining machinery, high-speed equipment, electronic production equipment, medical equipment

Merkmale

1. Geräuscharm

Das leichtgängige Reflow-Design der Umlenkung reduziert die durch den Betrieb der Stahlkugeln verursachten Aufprallgeräusche, die bei niedrigen Geschwindigkeiten fast nicht wahrnehmbar und bei hohen Geschwindigkeiten extrem gering sind.

2. Hohe Geschwindigkeit Das Reflow-Design und die aus verstärkten Materialien gefertigte Umlenkung ermöglichen den Betrieb bei DN-Werten von bis zu 180.000. **3. Kompakt und leicht** Die Form der Kugelmutter ist im Vergleich zur allgemeinen Strukturformel um 18%-30% reduziert, was für kleine XY-Werkbänke oder Instrumente mit verschiedenen kompakter Bauform bzw. wenig Bauraum geeignet ist.

Characteristics

1.Low noise

The smooth reflow design of the redirection reduces the impact noise caused by the operation of the steel balls, which is almost imperceptible at low speeds and extremely low at high speeds.

2.High speed

The smooth reflow design and the reverser made of reinforced materials allow the operation to run at DN values of up to 180,000.

3.Compact and lightweight

The shape of the ball nut is reduced by 18%-30% compared with the general structural formula, which is suitable for small workbenches and other equipment or instruments with various miniaturized designs.

Genauigkeitsklasse und Axialspiel

Index	Genauigkeitsklasse Accuracy class	Axial Spiel Axial clearance
Positionierung Positioning	C1, C2, C3, C4, C5	0mm(preload) / Vorspannung
Transport Transmission	T1, T2, T3, T4, T5, T7, T10	S:0~0.005mm, M:0~0.02mm, L:0~0.05mm

Accuracy class and axial clearance

Bei der Wahl der Genauigkeitsklasse ist auch die „maximale Fertigungslänge der Spindel“ zu berücksichtigen. Für Kugelgewindetriebe zur Positionierung werden in der Regel vorgespannte Produkte verwendet. Für Kugelgewindetriebe zum Transport werden in der Regel Produkte mit Spiel verwendet.

When selecting an accuracy class, it is also necessary to refer to the „maximum manufacturing length of the lead screw“. The positioning type ball screw pair generally uses preloaded products, and the transmission type ball screw pair generally uses gap products.

Konstruktion des Spindelendes

Bei der Gestaltung des Wellenendes der Kugelumlaufspindel ist darauf zu achten, dass mindestens ein Ende der Spindel einen vollständigen Gewindegang aufweist. Der Durchmesser der Welle an diesem Ende muss kleiner sein als der Kerndurchmesser der Laufbahn, damit die Kugelmutter montiert werden kann. Bei besonderen Anforderungen kann nach der Montage von Leitspindel und Mutter eine Wellenhülse an einem Ende des vollständigen Gewindes angebracht werden. Hinweis: Gegenwärtig bietet IF Produkte, mit denen unvollständige Zähne ohne Inlays an beiden Enden erlangt werden können.

Design Considerations for spindle end

When designing the shaft end of the ball screw, it must be ensured that at least one end of the lead screw is a complete tooth, and the diameter of each shaft at one end of the complete tooth must be smaller than the bottom diameter of the raceway groove, otherwise the ball nut cannot be assembled with the ball screw. If there are special requirements, the end of the complete thread (mostly the non-driven end) of the lead screw and nut can be fitted with a bushing after the lead screw and nut are assembled.

Note: At present, IF has developed some products that can obtain incomplete teeth without inlays at both ends.

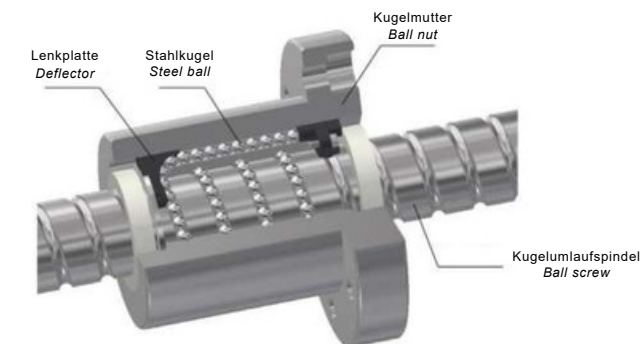

Einzelflanschmutter Single flange nut

FEEG

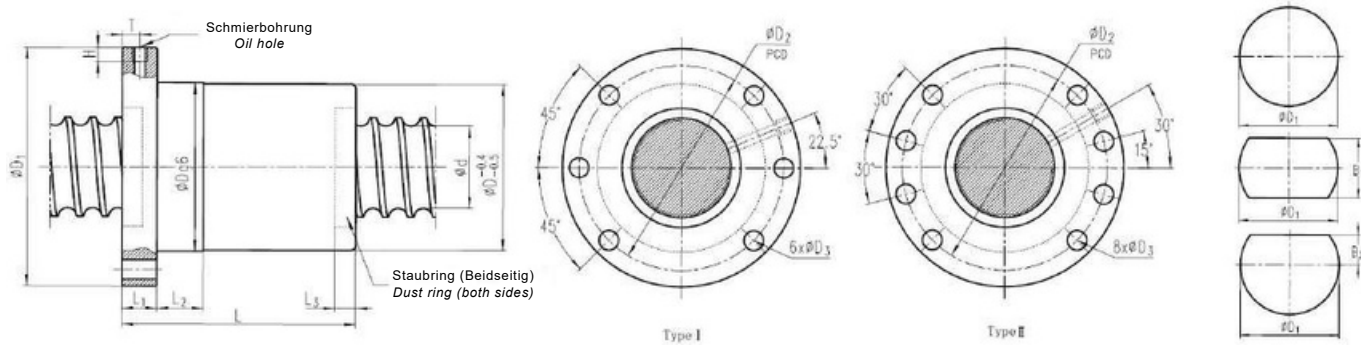

Doppel-Flanschmutter Double flange nut

FDEG

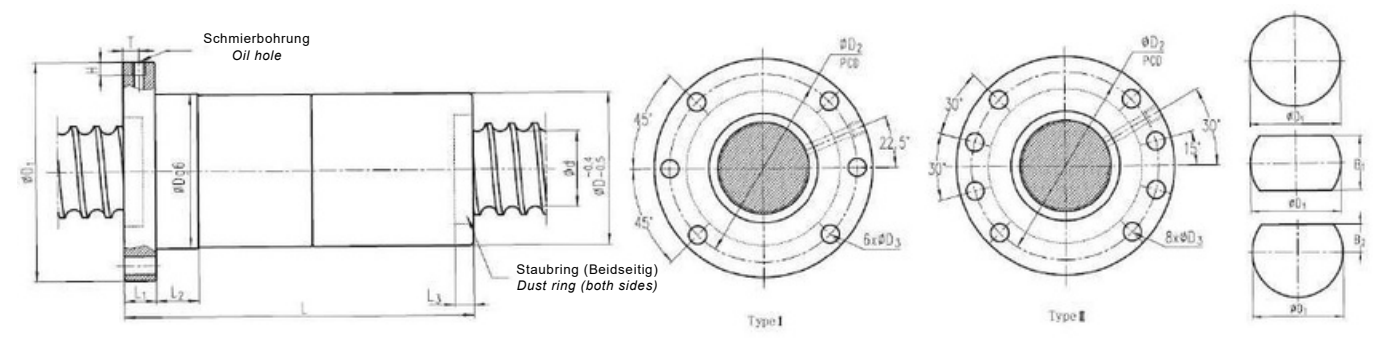

Index	Spindel Ball screw		Kugel- Ø Ball- ø	Umläufe Loaded turns	d	D	Flansch Flange						D3	Ölbohrung Oil hole		Schmierbohrung Lubrication hole	Nennlast rated load (N)		Steifigkeit Rigidity K N/µm		
	Nenn- ø Nominal- ø	Steigung Lead					D1	D2	B1	B2	L1	L2		L3	L		H	T		C _{dyn}	C _{stat}
FEEG20-5-3	20	5	3.175	3	17.2	36	62	49	48	24	12	12	6.5	37	5.5	8	6	M6×1	13100	20500	308
FEEG20-5-4	20	5	3.175	4	17.2	36	62	49	48	24	12	12	6.5	47	5.5	8	6	M6×1	16700	27300	406
FEEG25-5-4	25	5	3.175	4	22.2	40	62	51	48	24	12	15	6.5	43	6.6	8	6	M6×1	18600	34600	480
FEEG25-10-4	25	10	3.959	4	21.1	43	64	51	48	24	12	15	6.5	64	6.6	8	6	M6×1	24900	42500	511
FEEG25-12-4	25	12	3.959	4	21.1	43	64	51	48	24	12	15	6.5	72	6.6	8	6	M6×1	24800	42400	512
FEEG25-10-4	25	10	4.752	4	20.5	45	65	54	51	25.5	15	15	6.5	65	8	8	8	M6×1	31900	51500	529
FEEG32-5-4	32	5	3.175	4	29.2	50	87	72	69	34.5	16	15	6.5	43	9	10	8	M8×1	20700	44800	565
FEEG32-8-4	32	8	3.959	4	28.2	50	87	72	69	34.5	16	15	6.5	56	9	10	8	M8×1	28400	56300	614
FEEG32-8-5	32	8	3.959	5	28.2	50	87	72	69	34.5	16	15	6.5	64	9	10	8	M8×1	34400	70300	760
FEEG32-8-4	32	8	4.752	4	27.5	53	87	72	69	34.5	16	15	6.5	57	9	10	8	M8×1	35500	64800	614
FEEG32-8-5	32	8	4.752	5	27.5	53	87	72	69	34.5	16	15	6.5	65	9	10	8	M8×1	43000	81100	760
FEEG32-10-3	32	10	3	3	26.4	57	87	72	69	34.5	16	15	6.5	58	9	10	8	M8×1	40500	64500	494
FEEG32-10-4	32	10	6.35	4	26.4	57	87	72	69	34.5	16	15	6.5	68	9	10	8	M8×1	51900	86100	650
FEEG32-10-5	32	10	6.35	5	26.4	57	87	72	69	34.5	16	15	6.5	78	9	10	8	M8×1	62900	107000	805
FEEG32-16-4	32	16	4	4	37.2	65	102	83	74	37	18	20	8.5	90	11	10	9	M8×1	51500	85500	659
FEEG40-5-4	40	5	3.175	4	35.5	60	91	76	68	34	18	15	6.5	44	9	10	9	M8×1	22800	56400	654
FEEG40-5-4	40	5	3.175	4	35.5	60	91	76	68	34	18	15	6.5	49	9	10	9	M8×1	31000	70000	685
FEEG40-5-4	40	5	3.959	5	35.5	60	91	76	68	34	18	15	6.5	54	9	10	9	M8×1	37600	87500	849
FEEG40-8-4	40	8	4.752	4	35.5	60	91	76	68	34	18	15	6.5	58	9	10	9	M8×1	40100	84400	735
FEEG40-10-4	40	10	4	4	34.4	65	95	80	72	36	18	20	8.5	72	9	10	9	M8×1	58400	109000	768
FEEG40-10-5	40	10	4	5	34.4	65	95	80	72	36	18	20	8.5	80	9	10	9	M8×1	70700	136000	951
FEEG40-12-4	40	12	6.35	4	34.4	65	95	80	72	36	18	20	8.5	78	9	10	9	M8×1	58300	109000	778
FEEG40-16-4	40	16	4	4	34.4	65	95	80	72	36	18	20	8.5	94	9	10	9	M8×1	58000	108000	789
FEEG40-20-4	40	20	4	4	34.4	65	95	80	72	36	18	20	8.5	110	9	10	9	M8×1	57700	108000	792
FEEG50-5-4	50	5	3.175	4	47.2	70	106	88	80	40	18	20	6.5	45	10	11	10	M8×1	24900	70900	738
FEEG50-8-4	50	8	3.959	4	45.7	70	106	88	80	40	18	20	6.5	57	10	11	10	M8×1	34000	88100	817
FEEG50-8-4	50	8	4.752	4	45.5	70	106	88	80	40	18	20	6.5	58	10	11	10	M8×1	43500	104000	822
FEEG50-10-3	50	10	3	3	44.4	75	118	100	92	46	18	20	8.5	60	11	10	9	M8×1	50700	103000	679
FEEG50-10-4	50	10	4	4	44.4	75	118	100	92	46	18	20	8.5	70	11	10	9	M8×1	64900	138000	894
FEEG50-10-5	50	10	4	5	44.4	75	118	100	92	46	18	20	8.5	80	11	10	9	M8×1	78700	173000	1108
FEEG50-12-4	50	12	4	4	44.4	75	118	100	92	46	18	20	8.5	80	11	10	9	M8×1	64800	138000	912
FEEG50-16-4	50	16	6.35	4	44.4	75	118	100	92	46	18	20	8.5	95	11	10	9	M8×1	64700	138000	933
FEEG50-20-4	50	20	4	4	44.4	75	118	100	92	46	18	20	8.5	110	11	10	9	M8×1	64400	137000	943
FEEG50-30-4	50	30	4	4	44.4	75	118	100	92	46	18	20	8.5	152	11	10	9	M8×1	63700	136000	946
FEEG50-30-5	50	30	4	5	44.4	75	118	100	92	46	18	20	8.5	182	11	10	9	M8×1	77200	170000	1171
FEEG50-40-3	50	40	3	3	41.2	90	135	115	100	50	22	20	8.5	152	13	10	11	M8×1	50200	105000	733
FEEG50-16-4	50	16	9.525	4	38.9	100	138	118	105	54	20	25	10.5	102	13.5	10	12	M8×1	117000	213000	998
FEEG50-16-4	50	16	12.7	4	38.9	100	138	118	105	54	20	25	10.5	106	13.5	10	12	M8×1	160000	274000	1040
FEEG63-10-4	63	10	6.35	4	57.4	88	135	115	110	50	22	20	8.5	71	13.5	10	11	M8×1	72600	179000	1050
FEEG63-10-5	63	10	6.35	5	57.4	88	135	115	110	50	22	20	8.5	81	13.5	10	11	M8×1	88000	223000	1300
FEEG63-20-4	63	20	4	4	56.2	94	135	115	110	50	22	20	8.5	112	13.5	10	11	M8×1	84100	196000	1146
FEEG63-30-3	63	30	7.144	3	56.2	94	135	115	110	50	22	20	8.5	123	13.5	10	11	M8×1	65100	146000	883
FEEG63-30-4	63	30	7.144	4	56.2	94	135	115	110	50	22	20	8.5	153	13.5	10	11	M8×1	83400	195000	1163
FEEG63-40-3	63	40	4	3	54.2	102	147	127	112	56.5	22	20	8.5	153	13.5	10	11	M8×1	56000	150000	907
FEEG63-16-4	63	16	9.525	4	54.2	102	147	127	112	56.5	22	20	8.5	102	13.5	10	11	M8×1	132000	271000	1170
FEEG63-16-5	63	16	9.525	5	54.2	102	147	127	112	56.5	22	20	8.5	118	13.5	10	11	M8×1	160000	339000	1450
FEEG63-16-4	63	16	12.7	4	51.9	115	157	137	123	61.5	25	25	14.5	106	13.5	10	11	M8×1	181000	344000	1230
FEEG63-20-4	63	20	4	4	51.9	115	157	137	123	61.5	25	25	14.5	122	13.5	10	11	M8×1	181000	344000	1240
FEEG80-10-4	80	10	6.35	4	74.4	110	150	130	115	58	25	25	14.5	71	14.5	10	13	M8×1	79400	225000	1210
FEEG80-10-5	80	10	6.35	5	74.4	110	150	130	115	58	25	25	14.5	81	14.5	10	13	M8×1	96200	282000	1500
FEEG80-16-3	80	16	3	3	71.2	118	165	145	130	65	25	25	14.5	93	14.5	10	13	M8×1	114000	257000	1040
FEEG80-16-4	80	16	9.525	4	71.2	118	165	145	130	65	25	25	14.5	110	14.5	10	13	M8×1	146000	343000	1370
FEEG80-16-5	80	16	9.525	5	71.2	118	165	145	130	65	25	25	14.5	125	14.5	10	13	M8×1	177000	429000	1700
FEEG80-16-4	80	16	12.7	4	68.9	132	175	155	143	70	25	25	14.5	113	14.5	10	13	M8×1	203000	436000	1440
FEEG80-20-4	80	20	4	4	68.9	132	175	155	143	70	25	25	14.5	129	14.5	10	13	M8×1	203000	437000	1470

Hinweis: Die Spirallaufbahnen an beiden Enden der Leitspindel mit ★ Modell können für unvollständige Gewindegänge ausgewählt werden. Wenn die Anzahl der Züge nicht festgelegt ist, kann das Produkt je nach Kundenbedarf angepasst werden.

Note: The spiral raceways at both ends of the lead screw with ★ model can be selected for incomplete thread. If the number of trains is not selected, the product can be adjusted or negotiated according to customer needs.

Index	Spindel Ball screw		Kugel- Ø Ball- ø	Umläufe Loaded turns	d	D	Flansch Flange						D3	Ölbohrung Oil hole		Schmierbohrung Lubrication hole	Nennlast rated load (N)		Steifigkeit Rigidity K N/µm		
	Nenn- ø Nominal- ø	Steigung Lead					D1	D2	B1	B2	L1	L2		L3	L		H	T		C _{dyn}	C _{stat}
FDEG20-5-3	20	5	3.175	3	17.2	36	62	49	48	24	12	12	6.5	72	6.6	8	6	M6×1	13100	20500	460
FDEG20-5-4	20	5	3.175	4	17.2	36	62	49	48	24	12	12	6.5	82	6.6	8	6	M6×2	16700	27300	600
FDEG25-5-4	25	5	3.175	4	22.2	43	62	51	48	24	12	15	6.5	82	6.6	8	6	M6×1	18600	34600	716
FDEG25-10-4	25	10	3.959	4	21.1	43	64	51	48	24	12	15	6.5	121	6.6	8	6	M6×1	24900	42500	749
FDEG25-12-4	25	12	3.959	4	21.1	43	64	51	48	24	12	15	6.5	142	6.6	8	6	M6×1	24800	42400	749
FDEG25-10-4	25	10	4.752	4	20.5	45	65	54	51	25.5	15	15	6.5								

Zylindermutter

Cylindrical single nut

DEEG

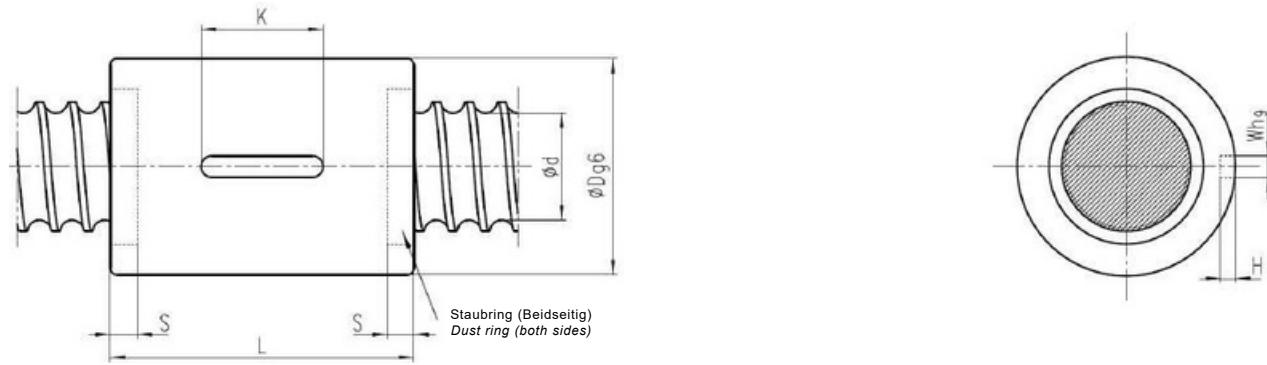

Index	Spindel Ball screw		Kugel- Ball- ø	Umläufe Loaded turns	d	D	K	W	H	S	L	Nennlast rated load (N)		Steifigkeit Rigidity K N/um			
	Nenn- ø Nominal- ø	Steigung Lead										C _{dyn}	C _{stat}				
DEEG20-5-3	20	5	3.175	3	17.2	36	20	3	1.8	6.5	39	13100	20500	210			
DEEG25-5-4	25	5	3.175	4	22.2	40	20	4	2.5	6.5	44	18600	34600	480			
DEEG25-10-4		10	3.969	4	21.1	43	25	4	2.5	6.5	64	24900	42500	511			
DEEG25-12-4		12		72							24800	42400	512				
DEEG25-10-4		10	4.762	4	20.5	45					65	31900	51500	529			
DEEG32-5-4		5	3.175	4	29.2	50					20	4	2.5	6.5	44	20700	44800
DEEG32-8-4	8	3.969	4	28.2	50	25					5	3	6.5	56	28400	56300	614
DEEG32-8-5	8		5				64	34400	70300	760							
DEEG32-8-4	8	4.762	4	27.5	53		57	35500	64800	614							
DEEG32-8-5	8		5				65	43000	81100	760							
DEEG32-10-3	10	6.35	3	26.4	57		25	6	3.5	6.5				58	40500	64600	494
DEEG32-10-4	10		4			68	51900				86100	650					
DEEG32-10-5	10		5			78	62900				107000	805					
DEEG32-16-4	16		4			90	51500				85500	659					
DEEG40-5-4	5		3.175			4	37.2				58	20	4	2.5	6.5	43	22800
DEEG40-6-4	6	3.969	4	35.8	58	25	5	3	6.5	48	31000	70000	685				
DEEG40-6-5	6		5							54	37600	87500	849				
DEEG40-8-4	8	4.762	4	35.5	62					58	40100	84400	735				
DEEG40-10-4★	10	6.35	4	34.4	65					32	6	3.5	8.5	71	58400	109000	768
DEEG40-10-5★	10		5											81	70700	136000	951
DEEG40-12-4★	12		4			79	58300	109000	540								
DEEG40-16-4★	16		4			95	58000	108000	789								
DEEG40-20-4	20		4			110	57700	108000	792								
DEEG50-5-4	5	3.175	4	47.2	70	20	4	2.5	6.5	45	24900	70900	738				
DEEG50-8-4	8	3.969	4	45.7	70	32	5	3	6.5	56	34000	88100	817				
DEEG50-8-4	8	4.762	4	45.5	75					58	43500	104000	844				
DEEG50-10-3★	10	6.35	3	44.4	75					32	6	3.5	8.5	60	50700	103000	679

Hinweis: Die Spirallaufbahnen an beiden Enden der Leitspindel mit ★ Modell können für unvollständige Gewindegänge ausgewählt werden. Wenn die Anzahl der Züge nicht festgelegt ist, kann das Produkt je nach Kundenbedarf angepasst werden.

Note: The spiral raceways at both ends of the lead screw with ★ model can be selected for incomplete thread. If the number of trains is not selected, the product can be adjusted or negotiated according to customer needs.

Zylindermutter

Cylindrical single nut

DEEG

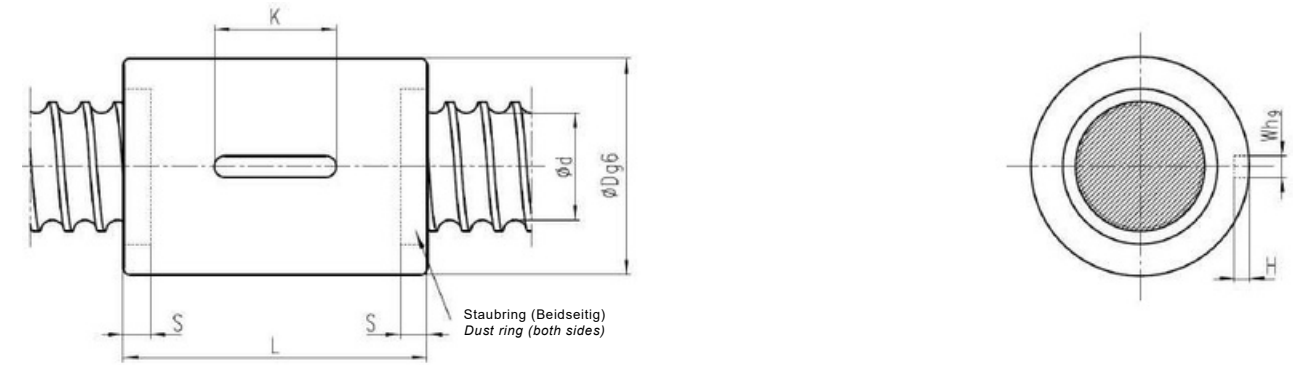

Index	Spindel Ball screw		Kugel- Ball- ø	Umläufe Loaded turns	d	D	K	W	H	S	L	Nennlast rated load (N)		Steifigkeit Rigidity K N/um							
	Nenn- ø Nominal- ø	Steigung Lead										C _{dyn}	C _{stat}								
DEEG50-10-4★	50	10	6.35	4	44.4	75	32	6	3.5	8.5	71	64900	138000	894							
DEEG50-10-5★		10		5							81	78700	173000	1108							
DEEG50-12-4★		12		4							79	64800	138000	664							
DEEG50-16-4		16		4							95	64700	138000	677							
DEEG50-20-4		20		4							111	64400	137000	648							
DEEG50-30-4		30		4							152	63700	136000	684							
DEEG50-30-5		30		5							182	77200	170000	847							
DEEG50-40-3		40		3							152	50200	105000	733							
DEEG50-16-4		16		9.525							4	41.2	90	50	8	4	10.5	101	111650	206580	1005
DEEG50-16-4		16		12.7							4	38.9	100	50	8	4	10.5	105	160000	274000	1040
DEEG63-10-4	63	10	7.144	4	56.2	94	40	8	4	8.5	71	72600	179000	1050							
DEEG63-10-5		10		5							81	88000	223000	1300							
DEEG63-20-4		20		4							112	84100	196000	841							
DEEG63-30-3		30		3							121	65100	146000	647							
DEEG63-30-4		30		4							151	83400	195000	852							
DEEG63-40-3		40		3							151	66000	150000	666							
DEEG63-16-4		16		9.525							4	54.2	102	50	8	4	10.5	102	124100	259330	1173
DEEG63-16-5		16									5							118	150350	324160	1453
DEEG63-16-4		16		12.7							4	51.9	115	50	10	5	10.5	105	181000	344000	1230
DEEG63-20-4		20									4							121	181000	344000	1240
DEEG80-10-4	80	10	6.35	4	74.4	110	32	8	4	8.5	71	79400	225000	1210							
DEEG80-10-5		10		5							81	96200	282000	1500							
DEEG80-16-3		16		3							95	109220	253290	1065							
DEEG80-16-4		16		9.525							4	71.2	121	50	10	5	14.5	110	139890	337720	1403
DEEG80-16-5		16									5							126	169480	422150	1738
DEEG80-16-4		16		12.7							4	68.9	132	63	10	5	14.5	113	203000	438000	1440
DEEG80-20-4		20									4							129	203000	437000	1470

Hinweis: Die Spirallaufbahnen an beiden Enden der Leitspindel mit ★ Modell können für unvollständige Gewindegänge ausgewählt werden. Wenn die Anzahl der Züge nicht festgelegt ist, kann das Produkt je nach Kundenbedarf angepasst werden.

Note: The spiral raceways at both ends of the lead screw with ★ model can be selected for incomplete thread. If the number of trains is not selected, the product can be adjusted or negotiated according to customer needs.

Doppel-Zylindermutter

Cylindrical double nut

DDEG

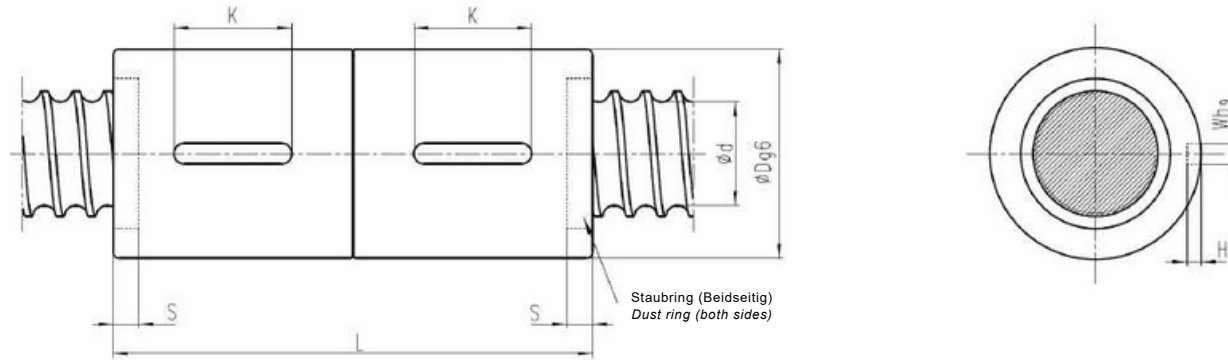

Hochgeschwindigkeits-Flanschmutter

High speed single nut

FEEH

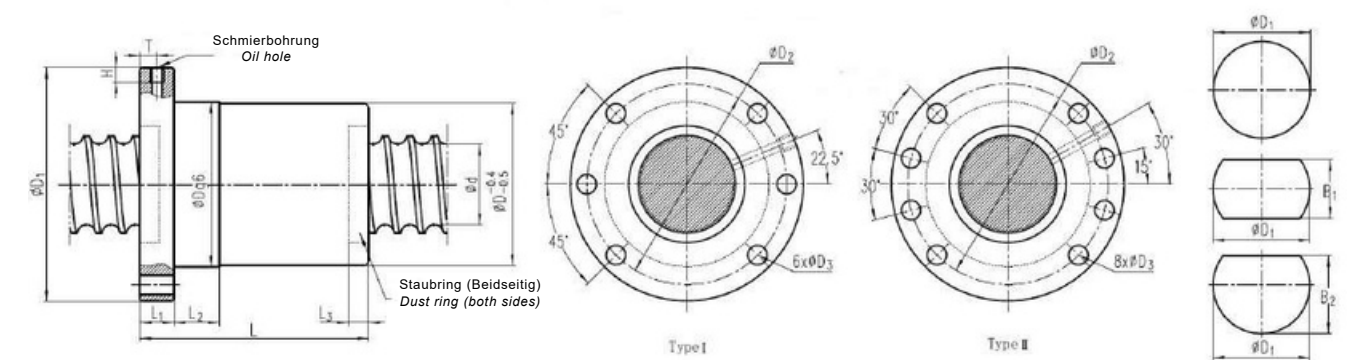

Index	Spindel Ball screw		Kugel- Ball- ϕ	Umläufe Loaded turns	d	D	K	W	H	S	L	Nennlast rated load (N)		Steifigkeit Rigidity K N/ μ m		
	Nenn- ϕ Nominal- ϕ	Steigung Lead										C _{dyn}	C _{stat}			
DDEG20-5-3	20	5	3.175	3	17.2	36	20	3	1.8	6.5	72	13100	20500	460		
DDEG25-5-4	25	5	3.175	4	22.2	43	20	4	2.5	6.5	82	18600	34600	716		
DDEG25-10-4		10	3.969	4	21.1	43	121				24900	42500	749			
DDEG25-12-4		12	4.762	4	20.5	45	142				24800	42400	749			
DDEG25-10-4		10		125			31900				51500	776				
DDEG32-5-4	32	5	3.175	4	29.2	50	20	4	2.5	6.5	83	20700	44800	853		
DDEG32-8-4		8	3.969	4	28.2		25	105	28400	56300	913					
DDEG32-8-5		8	4.762	5	27.5	53	32	121	34400	70300	1130					
DDEG32-8-4		8		4			25	113	35500	64800	911					
DDEG32-8-5		8	5	32	129	43000	81100	1120								
DDEG32-10-3		10	6.35	3	26.4	57	25	115	40500	64600	728					
DDEG32-10-4		10		4			135	51900	86100	959						
DDEG32-16-4		16		4			182	51500	85500	963						
DDEG40-5-4		5		3.175			4	37.2	60	20	4	2.5	6.5	90	22800	56400
DDEG40-6-4		40	6	3.969	4	35.8	60	25	5	3	8.5	98	31000	70000	1040	
DDEG40-8-4	8		4.762	4	35.5	62	114	40100	84400	1100						
DDEG40-10-4*	10		6.35	4	34.4	65	25	138	58400	109000		1140				
DDEG40-12-4*	12			4			149	58300	109000	1150						
DDEG40-16-4*	16			4			180	58000	108000	1150						
DDEG40-20-4	20			4			220	57700	108000	1150						
DDEG50-5-4	50	5	3.175	4	47.2	70	20	4	2.5	6.5	90	24900	70900	1140		
DDEG50-8-4		8	3.969	4	45.7	70	25	5	3	8.5	112	34000	88100	1240		
DDEG50-8-4		8	4.762	4	45.5	75	32	112	43500		104000	1270				
DDEG50-10-4*		10	6.35	4	44.4	75	40	139	64900		138000	1340				
DDEG50-12-4*		12		4				151	64800		138000	1360				
DDEG50-16-4		16		4				183	64700		138000	1380				
DDEG50-20-4		20		4				225	64400		137000	1380				
DDEG50-30-4		30	4	298	63700	136000	1380									
DDEG50-30-5		30	5	360	77200	170000	1710									
DDEG50-40-3		40	3	300	50200	105000	1060									
DDEG50-16-4		16	9.525	4	41.2	90	40	6	3.5		10.5	198	117000	213000	1470	
DDEG50-16-4		16	12.7	4	38.9	100	40	8	4		205	160000	274000	1540		
DDEG63-10-4		63	10	6.35	4	57.4	88	32	8		4	8.5	145	72600	179000	1600
DDEG63-20-4			20	7.144	4	56.2	94	40	8		4	8.5	220	84100	196000	1690
DDEG63-30-3			30		3								240	65100	146000	1290
DDEG63-30-4			30		4								300	83400	195000	1700
DDEG63-40-3	40		3		305								66000	150000	1320	
DDEG63-16-4	16		9.525	4	54.2	102	40	8	4	10.5	198	132000	271000	1740		
DDEG63-16-4	16		12.7	4	51.9	115	50	8	4	205	181000	344000	1820			
DDEG63-20-4	20		4	245	181000	344000	1840									
DDEG80-10-4	80		10	6.35	4	74.4	110	32	8	4	8.5	138	79400	225000	1860	
DDEG80-16-4			16	9.525	4	71.2	121	50	199	146000	343000	2060				
DDEG80-16-4		16	12.7	4	68.9	132	63	205	203000	438000	2160					
DDEG80-20-4		20	4	245	203000	437000	2190									

Index	Spindel Ball screw		Kugel- Ball- ϕ	Umläufe Loaded turns	d	D	Flansch Flange					L2	L3	L	D3	Obohrung Oil hole		Schmierbohrung Lubrication hole	Nennlast rated load (N)		Steifigkeit Rigidity K N/ μ m									
	Nenn- ϕ Nominal- ϕ	Steigung Lead					D1	D2	B1	B2	L1					H	T		C _{dyn}	C _{stat}										
FEEH40-12-4	40	12	6.35	4	34.4	70	112	90	86	100	18	20	8.5	81	17.5	9	10	M8x1	58300	109000	786									
FEEH40-12-5		12		5		70													86	100	18	20	8.5	93	17.5	9	10	70600	136000	973
FEEH40-16-4		16		4		75													90	100	18	20	98	58000	108000	799				

Hinweis: Die Spirallaufbahnen an beiden Enden der Leitspindel mit \star Modell können für unvollständige Gewindegänge ausgewählt werden. Wenn die Anzahl der Züge nicht festgelegt ist, kann das Produkt je nach Kundenbedarf angepasst werden.

Note: The spiral raceways at both ends of the lead screw with \star model can be selected for incomplete thread. If the number of trains is not selected, the product can be adjusted or negotiated according to customer needs.